

Parts for CP-0456 Scaler and Needle Scaler

WARNING
Exposure to vibration may be harmful to hands and arms.

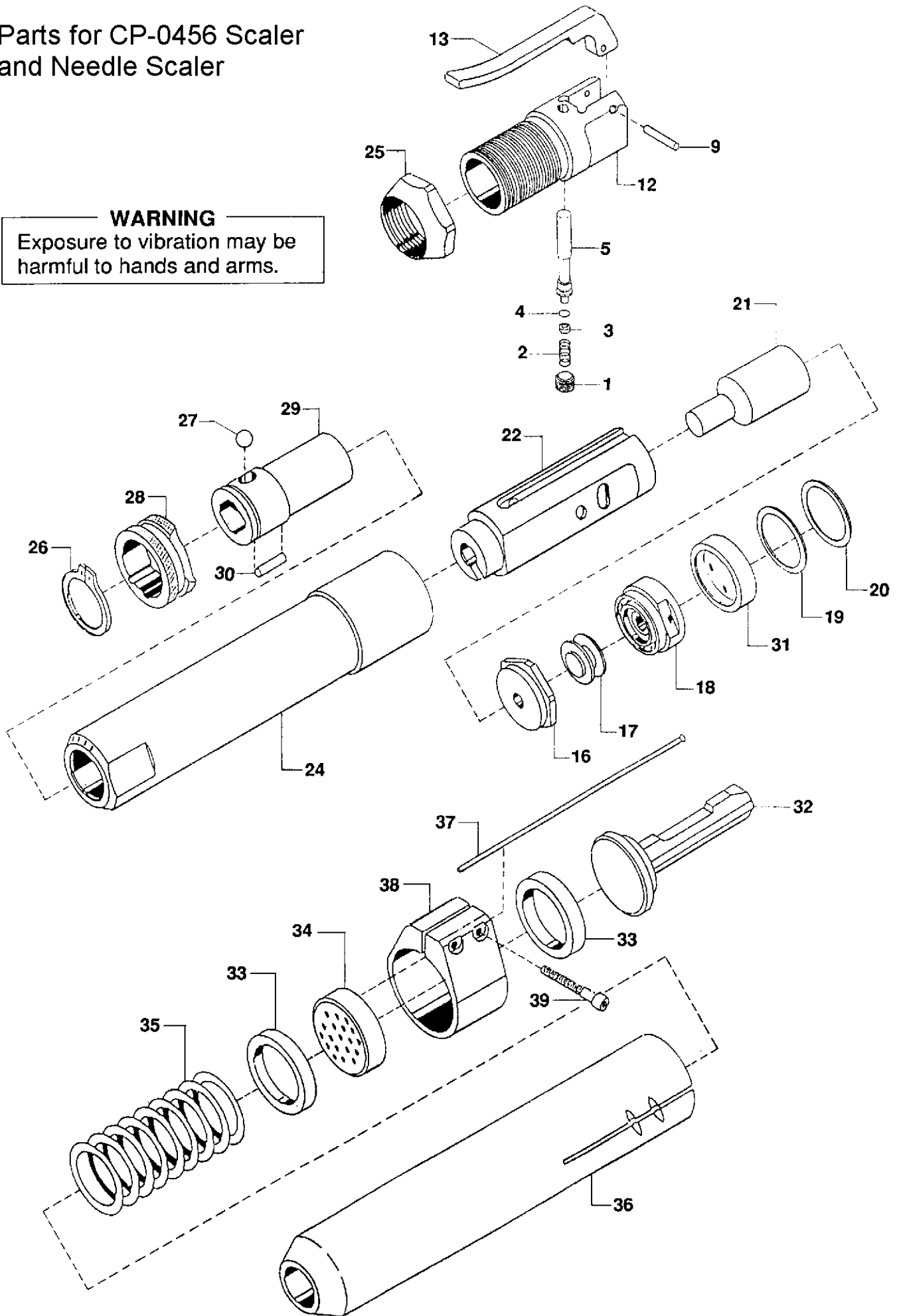

Parts for CP-0456 Scaler
and Needle Scaler

PART LIST

MODEL NUMBER	DESCRIPTION	QTY	REF. C.P. NO.
1.	Plug - Valve	1	P-009876
2.	Spring Valve	1	P-091585
3.	Cap - "O" Ring	1	P-091584
4.	"O" Ring	1	P-083076
5.	Throttle Valve	1	P-091582
9.	Pin - Throttle Lever	1	P-084043
12.	Backhead Model "B"	1	P-109273
13.	Throttle Lever	1	P-041556
15.	Allen Wrench (Not Shown)	1	P-070320
16.	Case Valve Cycling	1	P-084034
17.	Valve Cycling	1	P-043310
18.	Lid	1	P-043309
19.	Shim .005	1	P-084037
20.	Shim .010	1	P-084038
21.	Piston	1	P-084033
22.	Sleeve - Cylinder	1	P-041557
24.	Cylinder (Inc. sleeve) Model "B"	1	P-0113312
25.	Locknut Backhead Model "B"	1	P-109271
26.	Retaining Ring	1	P-050934
27.	Steel Ball	1	P-070416
28.	Ring Chisel Lock	1	P-088813
29.	Sleeve - Chisel 1/2" Q.O.	1	P-050933
30.	Lock Rubber	1	P-088815
31.	Spacer - Head Model "B"	1	P-125736
32.	Anvil	1	P-100144
33.	Buffer	2	P-100964
34.	Needle Holder	1	P-100145
35.	Needle Spring	1	P-100150
36.	Needle Housing (Round Nose)	1	P-117630
37.	Needle Set 7" 19 Steel Needles	1	P-100146
38.	Clamp - Needle Housing	1	P-117632
39.	Screw - Clamp	2	P-117633
40.	Allen Wrench (Not Shown)	1	P-070483

Part #

Description

S-4617
S-4105

Head Block Assembly (Includes Index No.'s 1, 2, 3, 4, 5, 9, 12, 13)
7" Needle Attachment with Round Housing (Includes Index No.'s 32, 33, 34, 35, 36, 37, 38, 39)